



## PORTABLE TYRE INFLATOR

### P/N OE52013

Type-approved automatic charging tyre inflator with 13-litre tank equipped with:

- ▶ pressure gauge ø 80 mm EEC approval certificate
- ▶ P/N OE52020 automatic charger

No.1 packing m<sup>3</sup> 0,088 kg 8,8 OVERALL DIMENSIONS P:310 H:750 L:310 mm



### P/N OE52020

Automatic charger for tyre inflator supplied with P/N OE52013

### HOW TO USE

The tyre inflation and deflating operations are done with single 3-position lever

- 1 IDLE**
- 2 DEFLATION**
- 3 INFLATION**

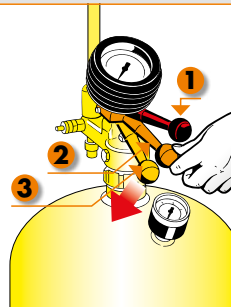

Tyre pressure control and/or inflation operations are carried out with the inflating gun

### INSTALLATION MEASURES for P/N OE52013

In order to have the tyre inflator always ready for use, just place it on the automatic charger as shown in the illustration

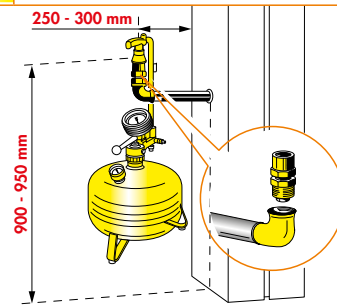

### P/N OE52015

Standard charging portable tyre inflator with 13-litre equipped with:

- ▶ gun with pressure gauge ø 60 mm **not type approved**

No.1 packing m<sup>3</sup> 0,088 kg 6,5 OVERALL DIMENSIONS P:310 H:600 L:310 mm



### P/N OE53016

Standard charging wheel-mounted tyre inflator with 13-litre tank equipped with:

- ▶ gun with **type approved** pressure gauge ø 60 mm

No.1 packing m<sup>3</sup> 0,088 kg 6,5 OVERALL DIMENSIONS P:310 H:600 L:310 mm



### P/N OE52024

Standard charging wheel-mounted tyre inflator with 24-litre tank equipped with:

- ▶ gun with pressure gauge ø 60 mm **not type approved**

No.1 packing m<sup>3</sup> 0,090 kg 10 OVERALL DIMENSIONS P:280 H:860 L:330 mm



### P/N OE53024

Standard charging wheel-mounted tyre inflator with 24-litre tank equipped with:

- ▶ gun with **type approved** pressure gauge ø 60 mm

No.1 packing m<sup>3</sup> 0,090 kg 10 OVERALL DIMENSIONS P:280 H:860 L:330 mm

